



## AS5160 / AS5160T

### PART LIST



Model: 50000398 / 50000403



Company information:  
[www.vipercleaning.eu](http://www.vipercleaning.eu)  
[info-eu@vipercleaning.com](mailto:info-eu@vipercleaning.com)

VS10016-EU  
Rev 01  
1 Jun 2016



# AS5160/AS5160T PARTS LIST

## GENERAL VIEW

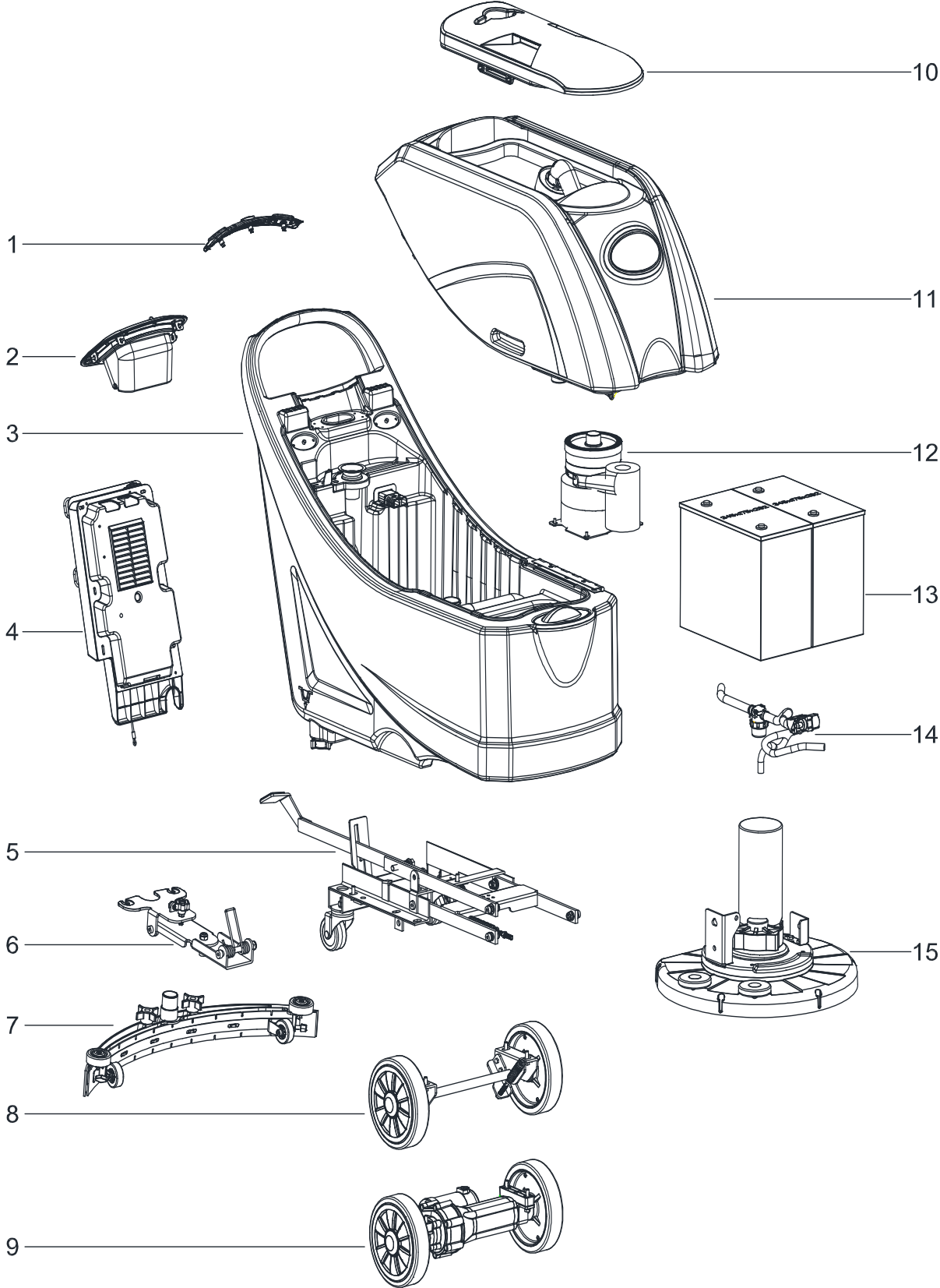

# AS5160/AS5160T PARTS LIST

---

## GENERAL VIEW

Item	Description	Qty
1A	SAFETY SWITCH ASSEMBLY WITHOUT TRACTION	1
1B	SAFETY SWITCH ASSEMBLY WITH TRACTION	1
2	CONTROL PANEL ASSEMBLY	1
3	SOLUTION TANK ASSEMBLY	1
4	CONTROL BOX ASSEMBLY	1
5	CHASSIS ASSEMBLY	1
6	SQUEEGEE HOLDER ASSEMBLY	1
7	20 INCH SQUEEGEE ASSEMBLY	1
8A	WHEEL ASSEMBLY WITHOUT TRACTION	1
9B	WHEEL ASSEMBLY WITH TRACTION	1
10	RECOVERY TANK LID ASSEMBLY	1
11	RECOVERY TANK ASSEMBLY	1
12	VACUUM MOTOR ASSEMBLY	1
13	BATTERIES	1
14	SOLUTION SYSTEM ASSEMBLY	1
15	BRUSH DECK ASSEMBLY	1

A : ONLY FOR MACHINE WITHOUT TRACTION

B : ONLY FOR MACHINE WITH TRACTION

# AS5160/AS5160T PARTS LIST

## SOLUTION TANK ASSEMBLY

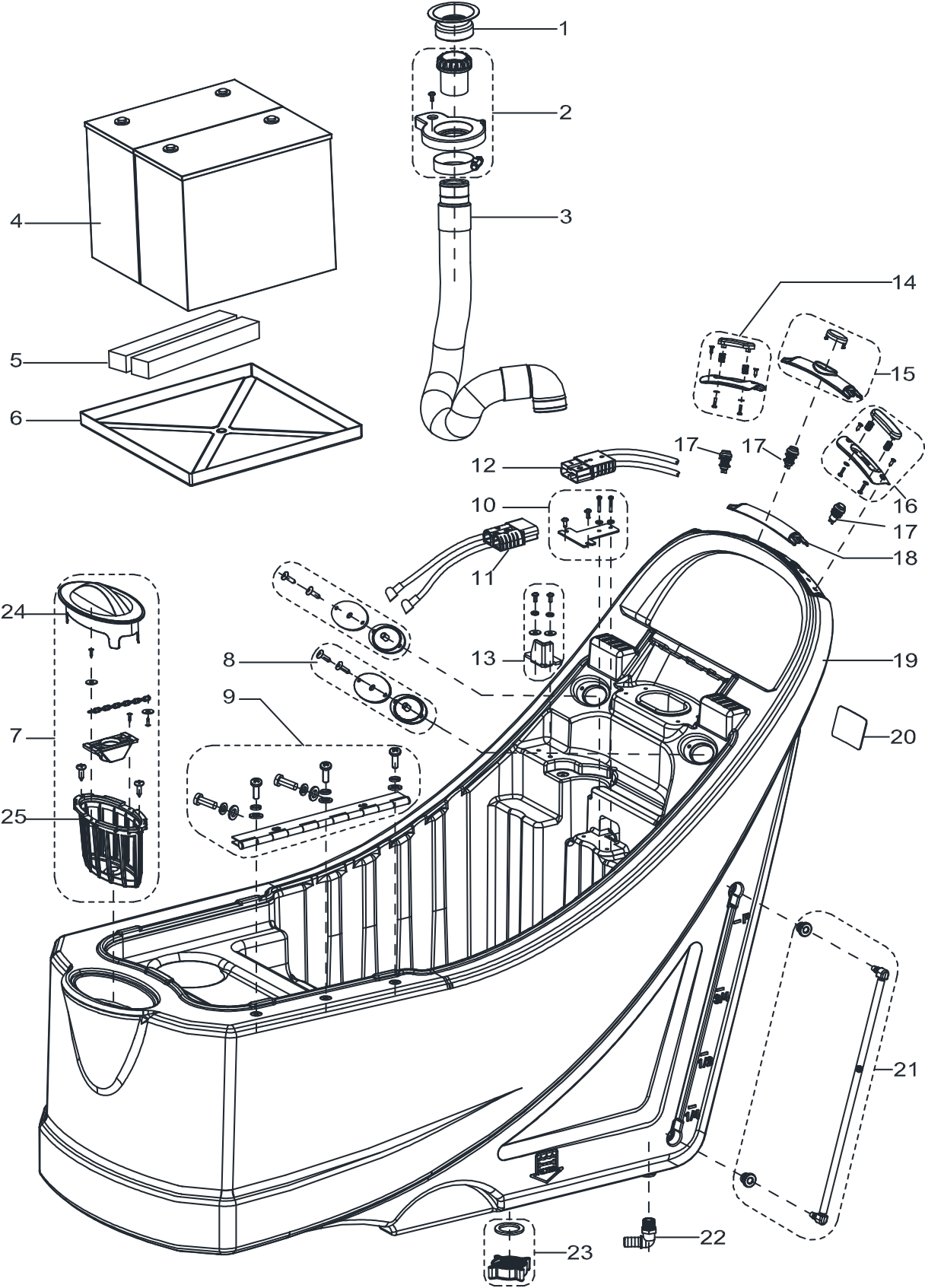

# AS5160/AS5160T PARTS LIST

## SOLUTION TANK ASSEMBLY

Item	Part No.	Description	Qty
1	VS10603	DRAIN HOSE GASKET	1
2	VS10101	SUCTION CONNECTER FRAME KIT	1
3	VS10601	SUCTION HOSE	1
4	N/A	BATTERY 100-115Ah/20h AGM	2
5	VF90533	BATTERY SPACER PANEL	2
6	VS10329	TRAY BATTERY	1
7	VS10102	FILTER COVER KIT	1
8	VF90265	SEAL PLATE KIT	2
9	VS10103	HINGE KIT	1
10	VS10104	CHARGE PULG BRACKET KIT	1
11	VS10206	BATTERY CONNECTIONS	1
12A	VS10217	HARNESS CONNECTER WITHOUT TRACTION	1
12B	VS10207	HARNESS CONNECTER WITH TRACTION	1
13	VS10105	FIXED BLOCK KIT	1
14	VS10106	SAFETY SWITCH RIGHT KIT	1
15B	VS11101	FRONT BACK SWITCH KIT	1
16	VS10108	SAFETY SWITCH LEFT KIT	1
17	VS10202	WATER-PROOF SWITCH	3
18A	VS10316	MIDDLE HANDLE COVER	1
19	VS10303	SOLUTION TANK	1
20	N/A	SERIAL NUMBER LABEL	1
21	VS10109	WATER LEVEL PIPE KIT	1
22	VF81403P	UNION ELBOW	1
23	VF90536	OUTLET COVER KIT	1
24	VS10312	FILTER COVER	1
25	VS10313	FILTER SUPPORT	1

A : ONLY FOR MACHINE WITHOUT TRACTION

B : ONLY FOR MACHINE WITH TRACTION

# AS5160/AS5160T PARTS LIST

## RECOVERY TANK ASSEMBLY

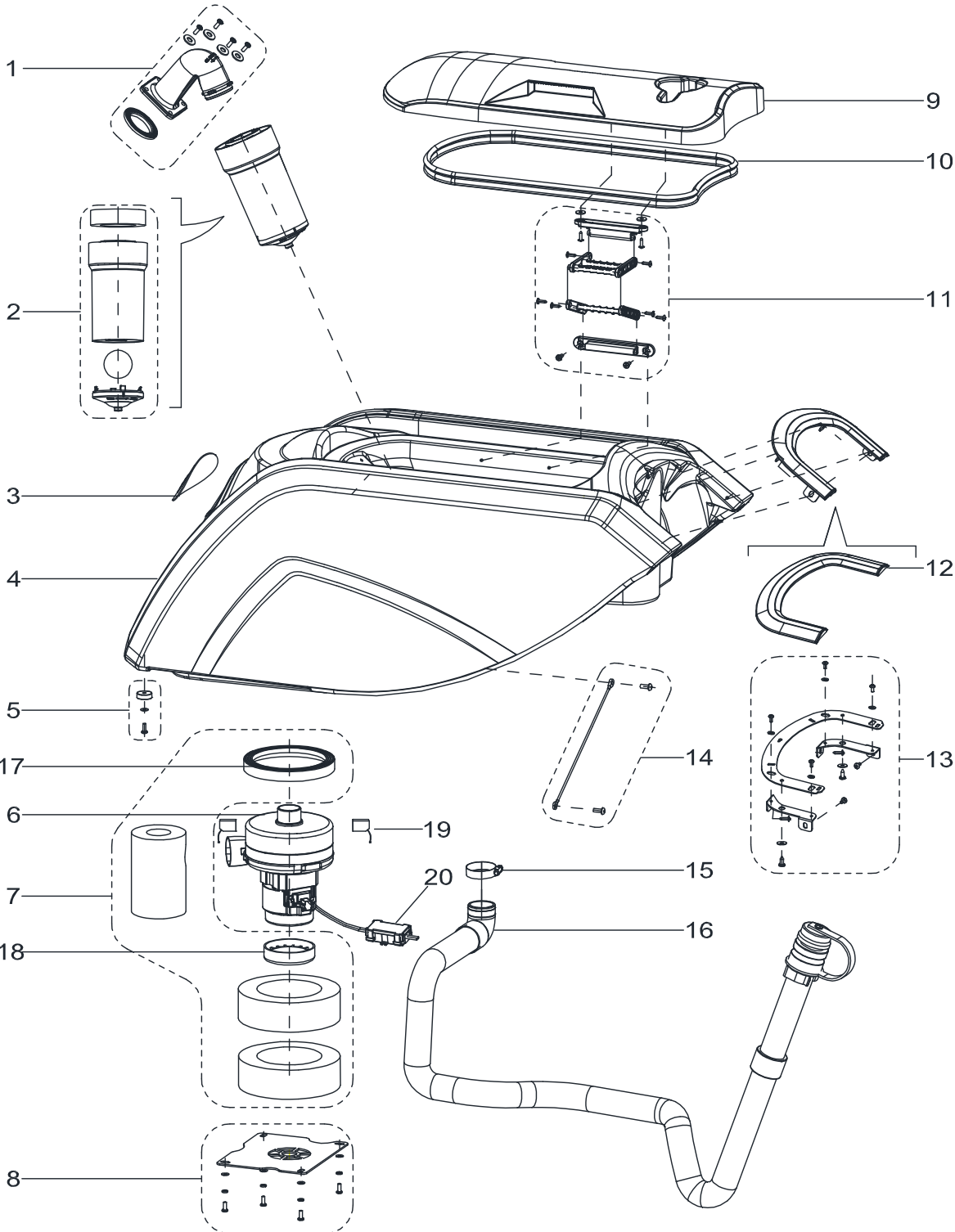

## AS5160/AS5160T PARTS LIST

---

### RECOVERY TANK ASSEMBLY

Item	Part No.	Description	Qty
1	VS10110	ELBOW ADAPTOR KIT	1
2	VF90534	FLOAT KIT	1
3	N/A	LOGO LABEL	1
4	VS10302	RECOVERY TANK	1
5	VS10111	RUBBER GASKET KIT	1
6	VF90520	VACUUM MOTOR	1
7	VS10112	GASKET VACUUM MOTOR KIT	1
8	VS10113	VACUUM MOTOR COVER KIT	1
9	VS10301	RECOVERY TANK LID	1
10	VF90504	GASKET	1
11	VS10114	CONNECTION FRAME KIT	1
12	VS10309	DECORATIVE PANEL	1
13	VS10115	DECORATIVE PANEL BRACKET KIT	1
14	VS10116	RECOVERY TANK CABLE KIT	1
15	VA20304	CLAMP	1
16	VS10602	DRAIN HOSE	1
17	VA80770	SUCTION UP GASKET	1
18	VF90523	TOP GASKET OF SUCTION MOTOR	1
19	VF90522	CARBON BRUSH KIT	2
20	VR27100	WATERPROOF CASE	1



# AS5160/AS5160T PARTS LIST

## CONTROL SYSTEM AND ELECTRICAL SYSTEM

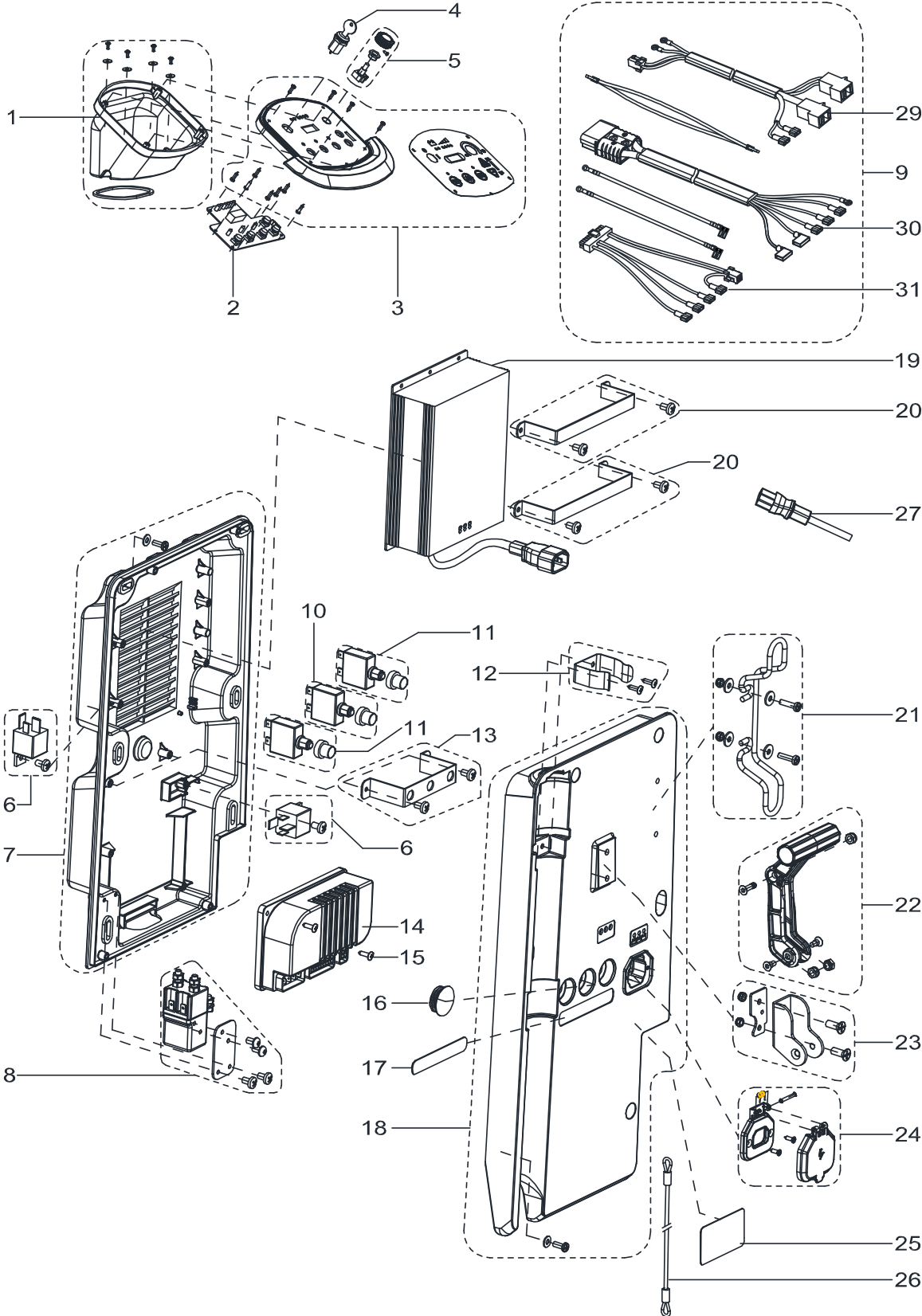

# AS5160/AS5160T PARTS LIST

## CONTROL SYSTEM AND ELECTRICAL SYSTEM

Item	Part No.	Description	Qty
1	VS10117	PCB BOX KIT	1
2	VS10203	CONTROL PANEL BOARD	1
3A	VS10118	CONTROL PANEL WITHOUT TRACTION	1
3B	VS11102	CONTROL PANEL WITH TRACTION	1
4	9100001354	KEY SWITCH	1
5B	VS10120	ADJUST SPEED KNOB KIT	1
6	VS10230	RELAY KIT	2
7	VS10121	CONTROL BOX BOTTOM KIT	1
8	VS10231	ELECTROMAGNETIC SWITCH KIT	1
9A	VS10233	HARNESS MACHINE KIT WITHOUT TRACTION	1
9B	VS11202	HARNESS MACHINE KIT WITH TRACTION	1
10B	VS11201	CIRCUIT BREAKER KIT WITH TRACTION	1
11	VS10232	CIRCUIT BREAKER KIT	2
12	VF90275	CLAMP DRAIN HOSE KIT	1
13	VS10122	FIX BRACKET KIT	1
14B	VS10209	ELECTRONIC BOARD WITH TRACTION SYSTEM	1
15	VA80758	SCREW PA4x16	2
16A	VF85128	CAP BLACK	1
17A	VS10002	RESET LABEL WITHOUT TRACTION	1
17B	VS11002	RESET LABEL WITH TRACTION	1
18	VS10124	CONTROL BOX COVER KIT	1
19	VR27041	CHARGER 24V 10A	1
19*	VS10204	CHARGER 24V 13A	1
20	VS10125	CHARGER FIX BRACKET KIT	2
21	VF90280	CABLE SUPPORT KIT	1
22	VF90277	HANDLE LIFT KIT	1
23	VF90276	HAND BRACKET KIT	1
24	VS10126	CHARGER SOKET KIT	1
25	VS10022	WARNING LABEL	1
26	VS10502	CABLE SQUEEGEE LIFT	1
27	VF89725	BATTERY CHARGING CABLE EU	1
27*	VF89726	BATTERY CHARGING CABLE UK	1

A : ONLY FOR MACHINE WITHOUT TRACTION

B : ONLY FOR MACHINE WITH TRACTION

## AS5160/AS5160T PARTS LIST

---

### CONTROL SYSTEM AND ELECTRICAL SYSTEM

29	VS10222	HARNESS BRUSH MOTER	1
30A	VS10217	HARNESS CONNECTER WITHOUT TRACTION	1
30B	VS10207	HARNESS CONNECTER WITH TRACTION	1
31A	VS10218	HARNESS CONTROL CIRCUIT WITHOUT TRACTION	1
31B	VS10208	HARNESS CONTROL CIRCUIT WITH TRACTION	1

A : ONLY FOR MACHINE WITHOUT TRACTION

B : ONLY FOR MACHINE WITH TRACTION

# AS5160/AS5160T PARTS LIST

## CHASSIS ASSEMBLY

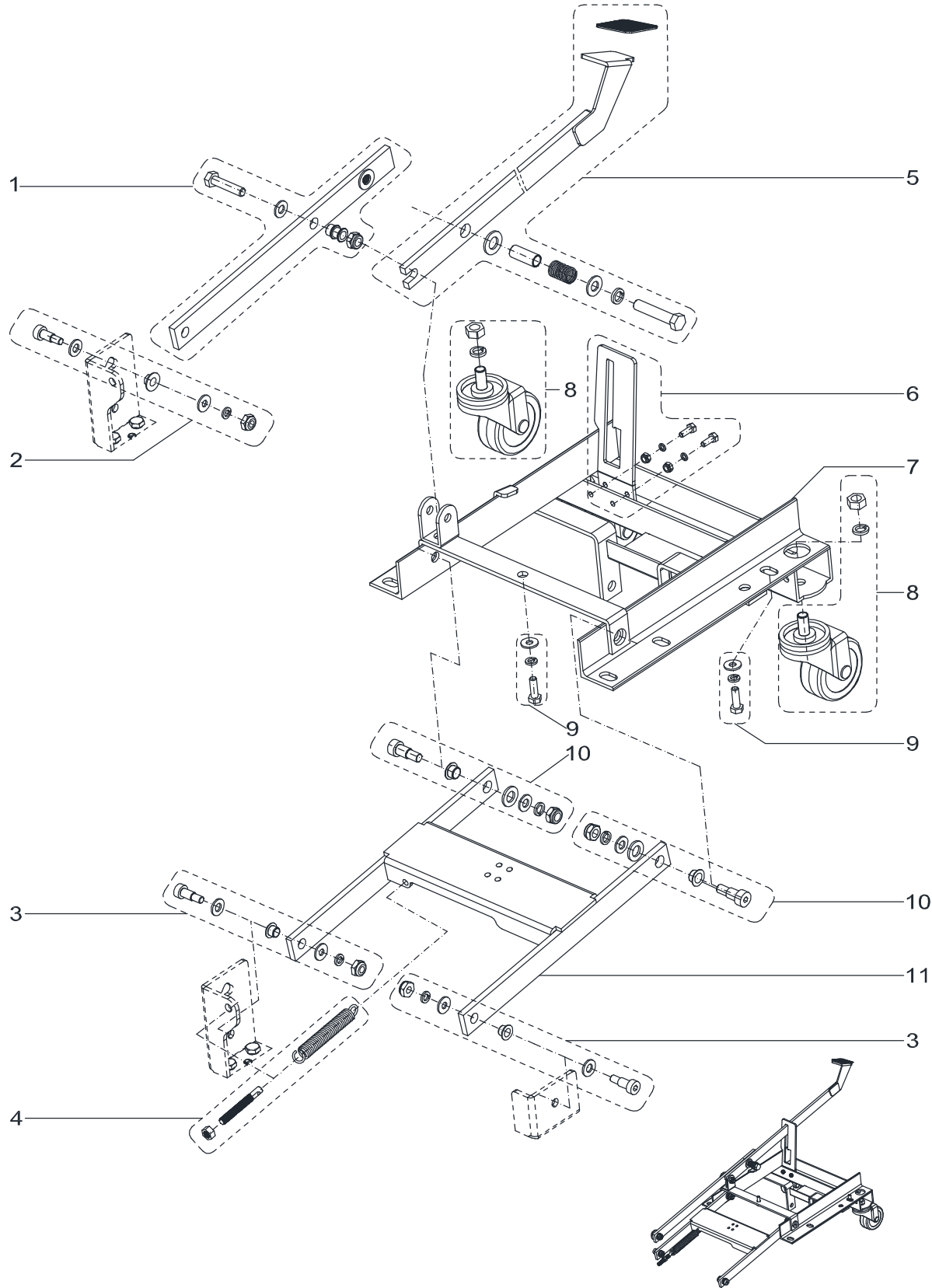

## AS5160/AS5160T PARTS LIST

### CHASSIS ASSEMBLY

Item	Part No.	Description	Qty
1	VS10138	FRONT PEDAL BRUSH LIFTING KIT	1
2	VS10134	SCREW KIT-1	1
3	VS10136	SCREW KIT-3	2
4	VS10139	SPRING KIT	1
5	VS10140	BACK PEDAL BRUSH LIFTING KIT	1
6	VS10141	PEDAL SUPPORT KIT	1
7	VS10406	CHASSIS	1
8	VS10142	3 INCH CASTER KIT	2
9	VS10135	SCREW KIT-2	1
10	VS10137	SCREW KIT-4	2
11	VS10404	BRUSH LIFTING SUPPORT	1

# AS5160/AS5160T PARTS LIST

## WHEEL ASSEMBLY (WITHOUT TRACTION)

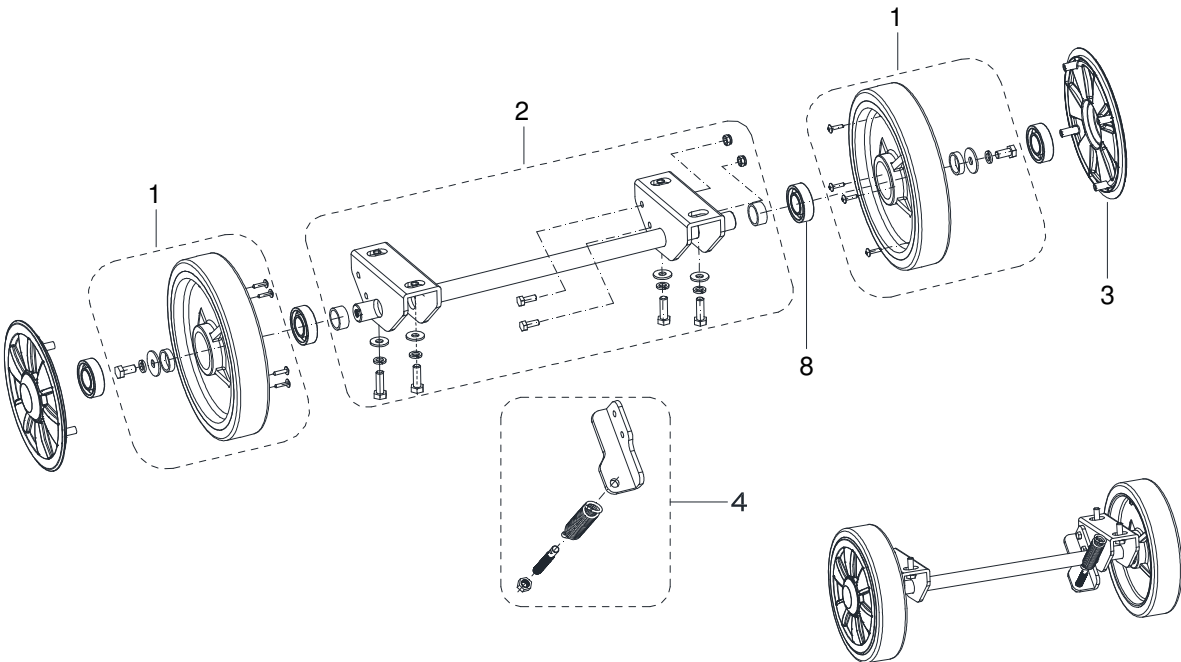

## WHEEL ASSEMBLY (WITH TRACTION)

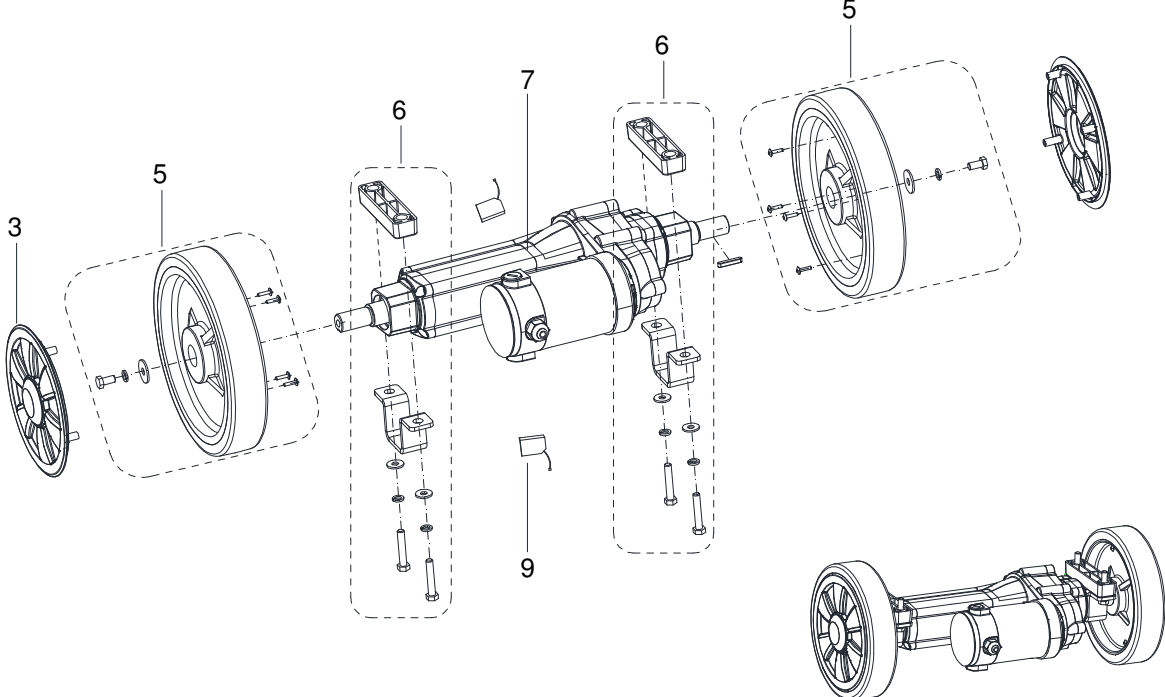

## AS5160/AS5160T PARTS LIST

---

### WHEELS ASSEMBLY

Item	Part No.	Description	Qty
1	VS10143	8 INCH WHEEL WITHOUT TRACTION KIT	2
2	VS10144	WHEEL SHAFT FIXED PLATE KIT	1
3	VS10330	WHEEL-COVER	4
4	VS10145	SPRING KIT	1
5	VS11103	8 INCH WHEEL WITH TRACTION KIT	2
6	VS10147	TRACTION MOUNT KIT	2
7	VS11702	MOTOR TRACTION	1
8	VF14075	BEARING 6004RS	4
9	VS11703	CARBON BRUSH KIT	2

# AS5160/AS5160T PARTS LIST

## SOLUTION ASSEMBLY

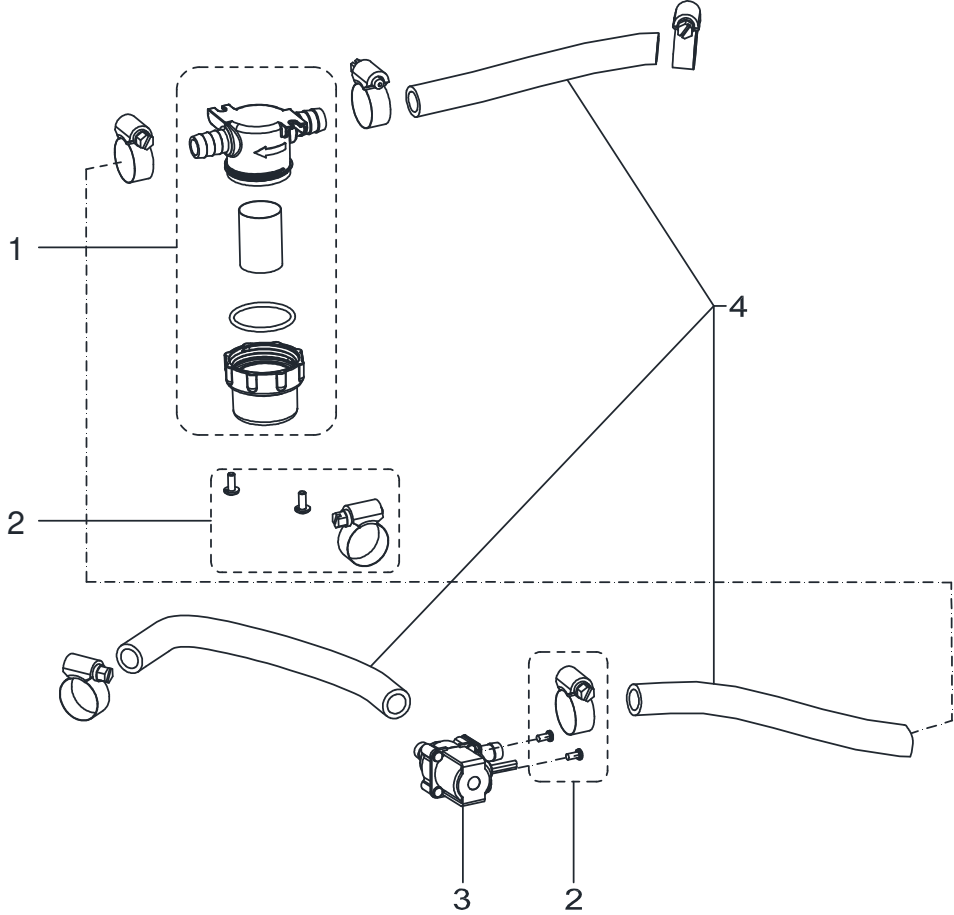
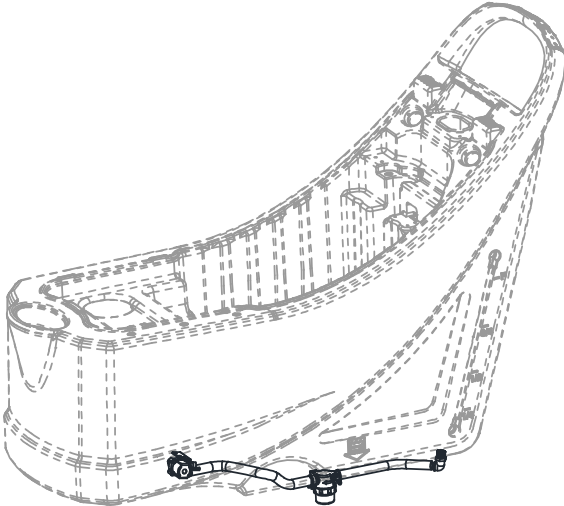



## AS5160/AS5160T PARTS LIST

---

### SOLUTION ASSEMBLY

Item	Part No.	Description	Qty
1	VF90621	FILTER KIT	1
2	VS10148	SCREW AND CLAMP KIT	1
3	VF90282	SOLENOID VALVE	1
4	VS10149	TUBE KIT	1

# AS5160/AS5160T PARTS LIST

## BRUSH ASSEMBLY

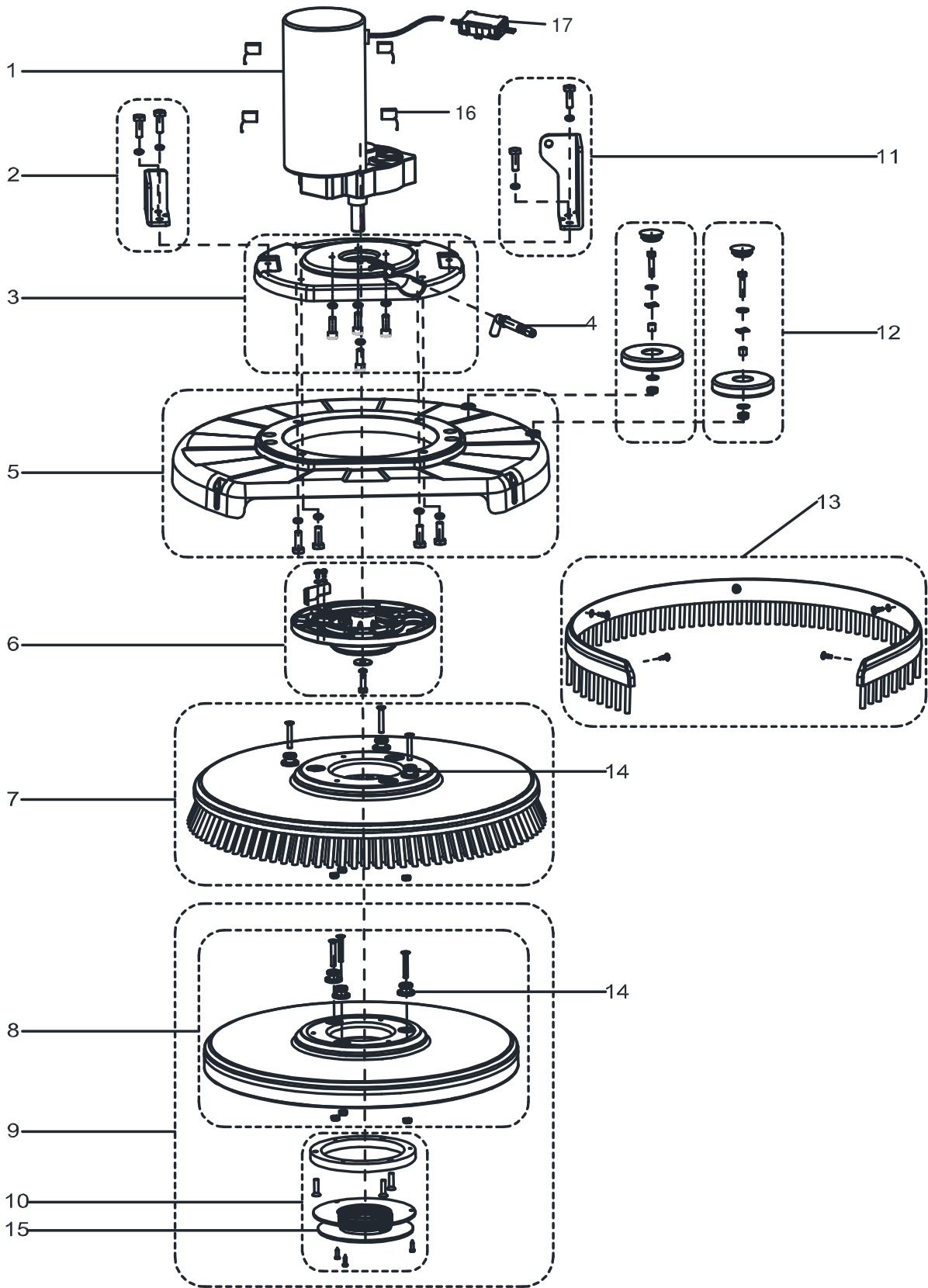

## AS5160/AS5160T PARTS LIST

---

### BRUSH ASSEMBLY

Item	Part No.	Description	Qty
1	VS10702	BRUSH MOTOR KIT	1
2	VS10132	SHORT CONNECTION PLATE KIT	1
3	VS10128	MOTOR FIXING PLATE KIT	1
4	VS10337	ELBOW	1
5	VS10129	BRUSH DECK KIT	1
6	VS10130	PLATE DRIVE KIT	1
7	VF90417	20 INCH BRUSH	1
8*	VF90416	20 INCH PAD	1
9*	VF90454	20 INCH PAD WITH RETAINER	1
10*	VS10131	RETAINER PAD KIT	1
11	VS10127	LONG CONNECTION PLATE KIT	1
12	VS10133	BUMPER ROLLER KIT	2
13*	VS10151	SKIRT KIT	1
14	VF90469	STUD	3
15	VF99003A	RETAINER PAD	1
16	VF89116	CARBON BRUSH KIT	4
17	VR27100	WATERPROOF CASE	1

# AS5160/AS5160T PARTS LIST

## SQUEEGEE ASSEMBLY

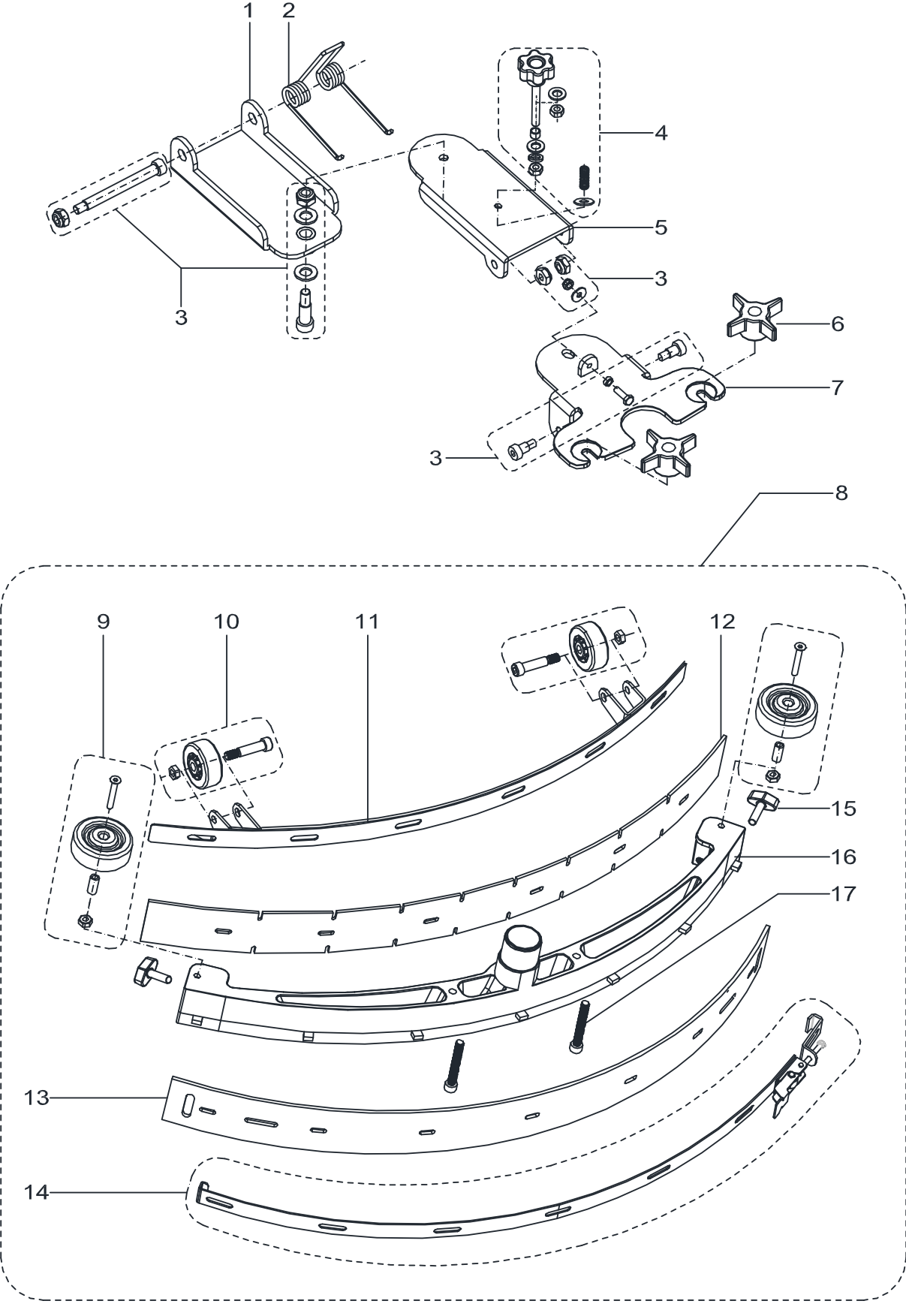

## AS5160/AS5160T PARTS LIST

### SQUEEGEE ASSEMBLY

Item	Part No.	Description	Qty
1	VS10401	FRONT-SQUEEGEE-SUPPORT	1
2	VF82172	SPRING 70°	1
3	VS13711	HARDWARE SQUEEGEE SUPPORT KIT	1
4	VF90141	HAND WHEEL KIT	1
5	VF90110	BACK-SQUEEGEE-SUPPORT	1
6	VF81210	KNOB	2
7	VF90109	SQUEEGEE-SUPPORT	1
8	VF90135	20 INCH SQUEEGEE KIT	1
9	VF90137	BUMPER ROLLER KIT	2
10	VF90136	SQUEEGEE ROLL WHEEL KIT	2
11	VF90118	20 INCH STRAP, SQUEEGEE FRONT	1
12	VF90119	20 INCH BLADE FRONT NR	1
12*	VF90148	20 INCH BLADE FRONT PU	1
13	VF90120	20 INCH BLADE REAR NR	1
13*	VF90149	20 INCH BLADE REAR PU	1
14	VF90139	20 INCH STRAP, SQUEEGEE BACK KIT	1
15	VF85420	WING NUT M8x30	2
16	VF90117	SQUEEGEE 20 INCH	1
17	VF90127	SQUEEGEE SCREW M8x65	2

# AS5160/AS5160T PARTS LIST

## WEAR AND TEAR PARTS

Item	Part No.	Description	Qty
1	VS10603	DRAIN HOSE GASKET	1
2	VS10601	SUCTION HOSE	1
3	VS10102	FILTER COVER KIT	1
4	VS10202	WATER-PROOF SWITCH	3
5	VS10109	WATER LEVEL PIPE KIT	1
6	VF90536	OUTLET COVER KIT	1
7	VS10110	ELBOW ADAPTOR KIT	1
8	VF90534	FLOAT KIT	1
9	VF90520	VACUUM MOTOR	1
10	VF90504	GASKET	1
11	VS10114	CONNECTION FRAME KIT	1
12	VS10602	DRAIN HOSE	1
13	VS10203	CONTROL PANEL BOARD	1
14	9100001354	KEY SWITCH	1
15	VS10230	RELAY KIT	2
16	VS10231	ELECTROMAGNETIC SWITCH KIT	1
17A	VS10233	HARNESS MACHINE KIT WITHOUT TRACTION	1
17B	VS11202	HARNESS MACHINE KIT WITH TRACTION	1
18B	VS11201	CIRCUIT BREAKER KIT WITH TRACTION	1
19	VS10232	CIRCUIT BREAKER KIT	1
20B	VS10209	ELECTRONIC BOARD WITH TRACTION SYSTEM	1
21	VR27041	CHARGER 24V 10A	1
22	VS10502	CABLE SQUEEGEE LIFT	1
23	VS10142	3 INCH CASTER KIT	2
24A	VS10143	8 INCH WHEEL WITHOUT TRACTION KIT	2
25B	VS11103	8 INCH WHEEL WITH TRACTION KIT	2
26B	VS11702	MOTOR TRACTION	1
27	VF90621	FILTER KIT	1
28	VF90282	SOLENOID VALVE	1
29	VS10702	BRUSH MOTOR KIT	1
30	VS10337	ELBOW	1
31	VF90417	20 INCH BRUSH	1
32	VF90454	20 INCH PAD WITH RETAINER	1
33	VS10133	BUMPER ROLLER KIT	2

A : ONLY FOR MACHINE WITHOUT TRACTION

B : ONLY FOR MACHINE WITH TRACTION

## AS5160/AS5160T PARTS LIST

### WEAR AND TEAR PARTS

34	VF90141	HAND WHEEL KIT	1
35	VF81210	KNOB	2
36	VF90137	BUMPER ROLLER KIT	2
37	VF90136	SQUEEGEE ROLL WHEEL KIT	2
38	VF90119	20 INCH BLADE FRONT NR	1
39	VF90120	20 INCH BLADE REAR NR	1
40	VF85420	WING NUT M8x30	2

A : ONLY FOR MACHINE WITHOUT TRACTION

B : ONLY FOR MACHINE WITH TRACTION

# AS5160/AS5160T PARTS LIST

## WIRING DIAGRAM ( MACHINE WITHOUT TRACTION )

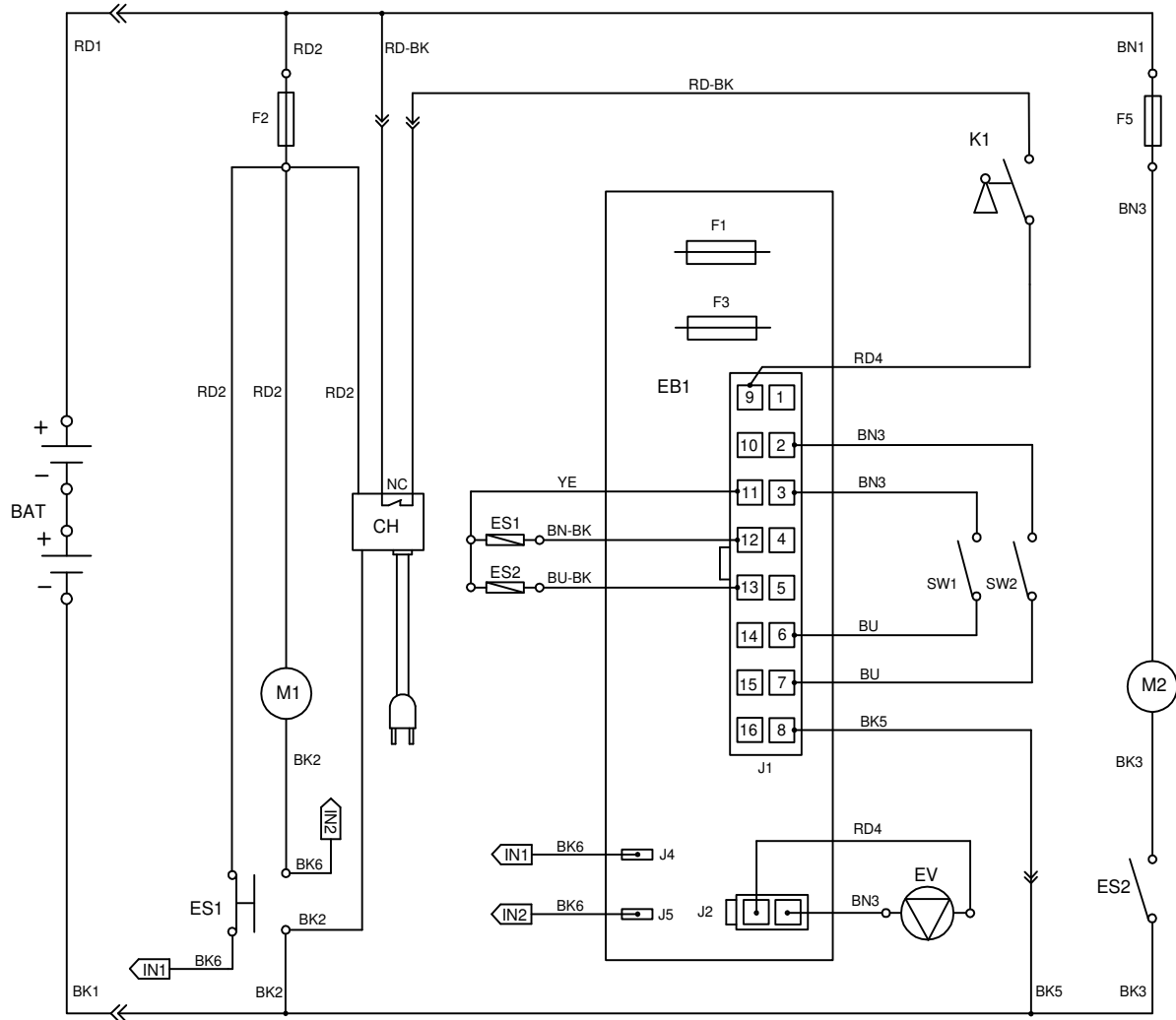

COMPONENTS		
Key	CODE	Description
BAT	N/A	24V BATTERIES
CH	VR27041	BATTERY CHARGER
EB1	VS10203	CONTROL PANEL BOARD
ES1	909 5127 000	ELECTROMAGNETIC SWITCH 24V(BRUSH MOTOR)
ES2	VS10201	RELAY 24V(VACUUM MOTOR)
F1	VS13208	LOW POWER CIRCUIT FUSE
F2	ZD48320	CIRCUIT BREAKER(BRUSH MOTOR)
F3	VS13209	BRUSH RELEASE FUSE
F5	ZD48320	CIRCUIT BREAKER(VACUUM MOTOR)
K1	910 0001 354	KEY SWITCH
M1	VS10702	BRUSH MOTOR
M2	VF90520	VACUUM MOTOR
EV	VF90282	SOLENOID VALVE
SW1	VS10202	SAFETY SWITCH(BRUSH)
SW2	VS10202	SAFETY SWITCH(BRUSH)

WIRE ROD	
RD1	RED/6AWG
RD2	RED/10AWG
RD4	RED/20AWG
BK1	BLACK/6AWG
BK2	BLACK/10AWG
BK3	BLACK/12AWG
BK5	BLACK/20AWG
BK6	BLACK/16AWG
RD-BK	RED-BLACK/20AWG
BN1	BROWN/12AWG
BN3	BROWN/20AWG
BN-BK	BROWN-BLACK/20AWG
BU	BLUE/20AWG
BU-BK	BLUE-BLACK/20AWG
YE	YELLOW/20AWG
WH	WHITE/20AWG



# AS5160/AS5160T PARTS LIST

## WIRING DIAGRAM (MACHINE WITH TRACTION)

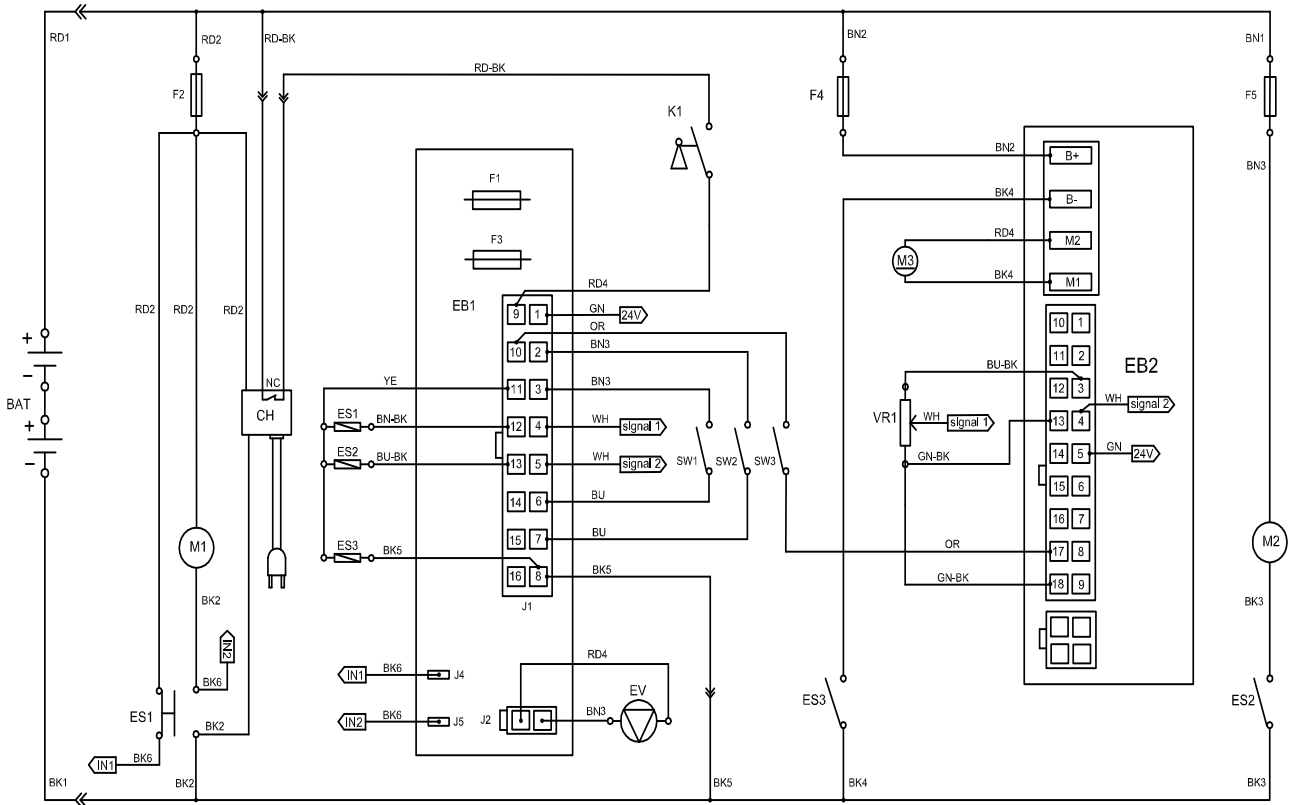

COMPONENTS		
Key	CODE	Description
BAT	N/A	24V BATTERIES
CH	VS10204	BATTERY CHARGER
EB1	VS10203	CONTROL PANEL BOARD
EB2	VS10209	ELECTRONIC BOARD(TRACTION SYSTEM)
ES1	909 5127 000	ELECTROMAGNETIC SWITCH 24V(BRUSH MOTOR)
ES2	VS10201	RELAY 24V(VACUUM MOTOR)
ES3	VS10201	RELAY 24V(TRACTION SYSTEM)
F1	VS13208	LOW POWER CIRCUIT FUSE
F2	ZD48320	CIRCUIT BREAKER(BRUSH MOTOR)
F3	VS13209	BRUSH RELEASE FUSE
F4	VF99012	CIRCUIT BREAKER(TRACTION SYSTEM)
F5	ZD48320	CIRCUIT BREAKER(VACUUM MOTOR)
K1	910 0001 354	KEY SWITCH
M1	VS10702	BRUSH MOTOR
M2	VF90520	VACUUM MOTOR
M3	VS11702	DRIVE MOTOR
EV	VF90282	SOLENOID VALVE
SW1	VS10202	SAFETY SWITCH(BRUSH/TRACTION)
SW2	VS10202	SAFETY SWITCH(BRUSH/TRACTION)
SW3	VS10202	REVERSING SWITCH
VR1	VS10213	SPEED POTENTIOMETER

WIRE ROD	
RD1	RED/6AWG
RD2	RED/10AWG
RD4	RED/20AWG
BK1	BLACK/6AWG
BK2	BLACK/10AWG
BK3	BLACK/12AWG
BK4	BLACK/14AWG
BK5	BLACK/20AWG
BK6	BLACK/16AWG
RD-BK	RED-BLACK/20AWG
GN	GREEN/20AWG
GN-BK	GREEN-BLACK/20AWG
BN1	BROWN/12AWG
BN2	BROWN/14AWG
BN3	BROWN/20AWG
BN-BK	BROWN-BLACK/20AWG
BU	BLUE/20AWG
BN-BK	BROWN-BLACK/20AWG
OR	ORANGE/20AWG
YE	YELLOW/20AWG
WH	WHITE/20AWG



**Company information:**  
[www.vipercleaning.eu](http://www.vipercleaning.eu)  
[info-eu@vipercleaning.com](mailto:info-eu@vipercleaning.com)

